

PROJECT	QUANTITY	ITEM NO
---------	----------	---------

Open Fryers

- OFE 141** 1-well electric
- OFE 141** 1-well electric built-in filtration
- OFE 142** 2-well electric
- OFE 142** 2-well electric built-in filtration



OFE 141 single well split vat electric open fryer with Computron™ 1500 control and optional built-in filtration

Henny Penny open fryers offer high-volume frying with simple programmable operation and fast, easy filtering with optional built-in filtration. The OFE 140 Series open fryers are available in full vat or split vat configuration. The split vat choice gives you the flexibility to fry smaller batches of different products in separate environments at the same time—a great way to multiply your profits with one fryer. Henny Penny open fryers recover temperature very quickly. Fast recovery translates into higher throughput, lower energy costs and longer frying oil life. Optional built-in filtration system quickly drains, filters and returns hot frying oil with no separate pumps or pans required. Frequent filtering

extends frying oil life, improves product quality and reduces oil costs. The OFE 140 Series open fryers feature a heavy-duty stainless steel fry pot that promotes fast even cooking. The Computron™ 1500 control offers programmability in an easy-to-use digital control panel with LED display.

Standard Features

- Heavy-duty stainless steel vat(s)
- Available with full or split vat(s)
- Hinged elements for easy vat cleaning
- Cold zone below heating elements helps extend oil life
- Computron™ 1500 control
 - Programmable
 - LED Time/Temp display
 - Simple UP/DOWN arrows
- Stainless steel construction for easy-cleaning and long life
- 4 heavy-duty casters, 2 locking
- 1-year warranty, parts and labor

Optional filtration

- Built-in filtration (additional charge)
 - Includes
 - Separate pump switch
 - Drain pan with cover
- Without built-in filtration

Drain height clearance: 318 mm (12.5 in)

Accessories shipped with unit

- Fry baskets—please select one
 - OFE 141
 - 1 full basket
 - 2 half baskets
 - OFE 142
 - 2 full baskets
 - 1 full and 2 half baskets
 - 4 half baskets
- 1 basket support for each vat
- Lift tool for electric element

Accessories available separately

- Fry well cover

<input type="checkbox"/> APPROVED <input type="checkbox"/> APPROVED AS NOTED <input type="checkbox"/> RESUBMIT	
AUTHORIZED SIGNATURE	DATE



Open Fryers

OFE 141 1-well electric
OFE 141 1-well electric built-in filtration
OFE 142 2-well electric
OFE 142 2-well electric built-in filtration

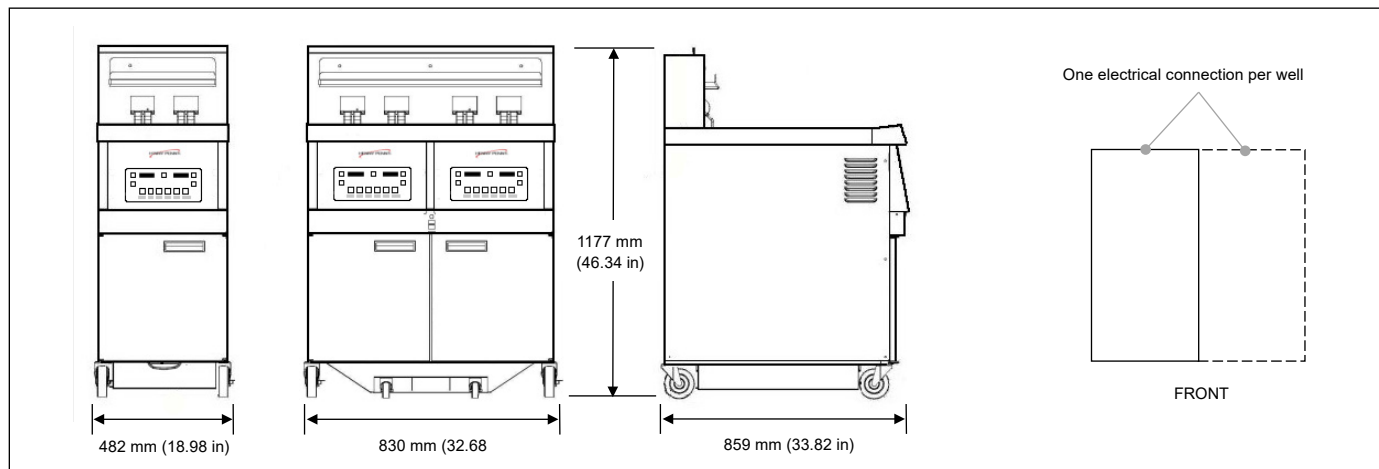

	OFE 141		OFE 142	
Dimensions				
Width	482 mm	(18.98 in)	830 mm	(32.68 in)
Depth	859 mm	(33.82 in)	859 mm	(33.82 in)
Height	1177 mm	(46.34 in)	1177 mm	(46.34 in)
Crated				
Length	950 mm	(37 in)	950 mm	(37 in)
Depth	600 mm	(24 in)	930 mm	(36.50 in)
Height	1325 mm	(52 in)	1325 mm	(52 in)
Volume	0.75 m ³	(27 ft ³)	1.17 m ³	(38 ft ³)
Weight*	120 kg	(264 lb)	210 kg	(462 lb)

*Includes optional built-in filtration. Contact Henny Penny for crated weight without built-in filtration.

Oil capacity

Per full vat 27 L or 25 kg (29 qt or 55 lb)

Per split vat 13 L or 12 kg (14 qt or 27 lb)

Heating immersed elements

14.0 kW total

28.0 kW total

Bidding specifications

Provide Henny Penny model OFE 141 single well or OFE 142 2-well electric open fryer. Unit may be ordered with full or split vat(s). Unit may be ordered with built-in filtration system for additional charge.

Unit shall incorporate:

- Computron™ 1500 digital control with press key function and LED display
- Heavy duty stainless steel fry vats
- Stainless steel construction throughout
- 4 heavy-duty casters, 2 locking
- 1-year warranty, parts and labor

Electrical

Volts	Phase	Hertz	kW per vat	Amps per vat	Wire*	Cord & Plug Not available for all destinations
230	3	50	14.0	35.1	3+G	Please contact Henny Penny
380	3	50	14.0	21.2	3NG	
400	3	50	14.0	20.2	3NG	
415	3	50	14.0	19.45	3NG	

Laboratory certifications



*Units shipped without power cord and plug must have power cord and plug installed on site by a qualified electrician.

Continuing product improvement may subject specifications to change without notice.

Henny Penny Suzhou Corporation
 No. 9 Hengpu Lane, Qingqiu Avenue
 SIP, Suzhou, China (215126)

+86 512 89180268 +86
 512 89180270 Fax
www.hennypenny.com