

PROJECT	QUANTITY	ITEM NO
---------	----------	---------

# Open Fryers



**OFE 321** 1-well electric  
**OFE 322** 2-well electric  
**OFE 323** 3-well electric



OFE 322 2-well electric open fryer with split vats and Computron™ 1000 control

Henny Penny open fryers offer high-volume, integral multi-well frying with programmable operation, oil management functions and fast, easy filtration.

The OFE 320 series open fryers are available in 1, 2, or 3-well, full and split vat configurations. Split vats in a multi-well fryer give you the flexibility to fry smaller batches of different products in separate environments at the same time—a great way to multiply your profits with one fryer.

Henny Penny electric open fryers recover temperature very quickly, and have earned the ENERGY STAR® mark for energy efficiency. Fast recovery translates into higher throughput, lower energy costs and longer frying oil life.

Heavy duty stainless steel vats come with a 7-year warranty—the best in the business.

Henny Penny open fryers have a built-in filtration system that filters and returns hot frying oil in minutes. No separate pumps and pans, no handling hot oil. Frequent filtering extends frying oil life, improves product quality and reduces oil costs. The Computron™ 8000 control features automatic, programmable operation, as well as energy-saving, filtration and cook management functions.

The Computron™ 1000 control offers programmability in a simple, easy to use digital control panel with LED display.

## Standard Features

- Heavy-duty stainless steel vats with 7-year warranty
- Full vat, split vat or combination
  - All full split
  - Left well full split
  - Middle well full split
  - Right well full split
- High-efficiency heating elements generate fast recovery and energy savings
- Cold zone below heating elements helps extend oil life
- High-limit temperature protection
- Built-in filtration system Single vat/sequential filter pan 2 or 3-vat filter pan
- Easy basket set and release
- Stainless steel construction for easy-cleaning and long life
- 4 heavy-duty casters, 2 locking

- Computron™ 8000 control (additional charge)
  - 12 programmable cook cycles
  - Melt mode
  - Idle mode
  - Clean-out mode
  - Load compensation
  - Proportional control
  - Optional filter prompt and customizable filter tracking
  - 16-character digital display with multiple language settings
- Computron™ 1000 control
  - Programmable
  - LED Time/Temp display
  - Simple UP/DOWN arrows

## Accessories shipped with unit

- Fry baskets—please select one
  - 1 full basket per well
  - 2 half baskets per well
- 1 basket support for each vat
- Filter screen and filter envelope

## Options available separately

- Fryer Shortening Shuttle®
- Fry well covers
- Choose one:
  - Filter rinse hose OR
  - Direct Connect shortening disposal

<input type="checkbox"/> APPROVED	<input type="checkbox"/> APPROVED AS NOTED	<input type="checkbox"/> RESUBMIT
AUTHORIZED SIGNATURE		DATE



PROJECT

ITEM NO

# Open Fryers

**OFE 321** 1-well electric  
**OFE 322** 2-well electric  
**OFE 323** 3-well electric

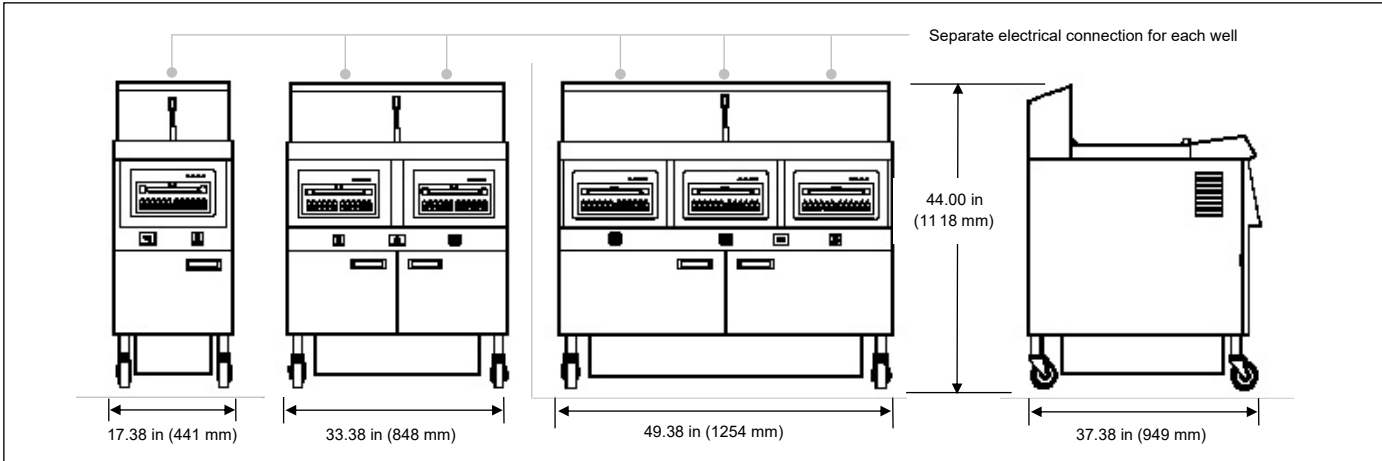

	OFE 321	OFE 322	OFE 323
<b>Dimensions</b>			
Width	17.38 in (441 mm)	33.38 in (848 mm)	49.38 in (1254 mm)
Depth	37.38 in (949 mm)	37.38 in (949 mm)	37.38 in (949 mm)
Height	44.00 in (1118 mm)	44.00 in (1118 mm)	44.00 in (1118 mm)
<b>Crated</b>			
Length	40 in (1016 mm)	40 in (1016 mm)	55 in (1397 mm)
Depth	25 in (635 mm)	39 in (991 mm)	39 in (991 mm)
Height	53 in (1346 mm)	54 in (1372 mm)	54 in (1372 mm)
Volume	31 ft <sup>3</sup> (0.86 m <sup>3</sup> )	49 ft <sup>3</sup> (1.4 m <sup>3</sup> )	67 ft <sup>3</sup> (1.9 m <sup>3</sup> )
Weight	281 lb (128 kg)	407 lb (185 kg)	523 lb (237 kg)
<b>Heating immersed elements</b>			
Output	14.4 kW total	28.8 kW total	43.2 kW total

## Oil capacity

Per full vat 65 lb or 30 L

Per split vat 25 lb or 12 L

## Required clearances

Sides N/A

Back N/A

Front 30 in (762 mm) remove filter pan

## Bidding Specifications

Provide Henny Penny model OFE 321, 322, or 323 electric open fryer with built-in filtration system. Unit may be ordered with full or split vat(s).

Unit shall incorporate:

- Computron™ 1000 simple digital control OR Computron™ 8000 control system (additional charge) with programmable or manual operation, LED digital display, idle and melt modes, load compensation, filtration tracking and 7-day history
- Fry vats of heavy duty stainless steel with 7-year warranty
- Single vat/sequential filter pan for single or multi-well fryers OR multi-vat filter pan
- Unit qualifies for the ENERGY STAR® mark
- 4 heavy-duty casters, 2 locking

## Electrical

Volts	Phase	Hertz	kW per well		Amps per well		Wire*	Cord & Plug
			full	split	full	split		Not available for all destinations
208	3	60	14.4	14.0	39.9	38.9	3+G	Please contact Henny Penny
220-240	3	50/60	14.4	14.0	37.2	33.7	3+G	
240	3	60	14.4	14.0	37.2	33.7	3+G	
400	3	50-60	14.4	14.0	23	22.5	3NG	
440-480	3	60	14.4	N/A	17.5	N/A	3+G	

## Laboratory certifications



\*Separate electrical connection required for each well. Units shipped without power cord and plug must have power cord and plug installed on site by a qualified electrician.

Continuing product improvement may subject specifications to change without notice.

**24 Hour Technical Support:**  
 Henny Penny Technical Service  
 800 417.8405  
[technicalservices@hennypenny.com](mailto:technicalservices@hennypenny.com)

**Henny Penny Corporation**  
 PO Box 60 Eaton OH 45320 USA  
 +1 937 456.8400 800 417.8417  
 +1 937 456.8434 Fax 800 417.8434 Fax  
[www.hennypenny.com](http://www.hennypenny.com)

**HENNY PENNY**