

PROJECT	QUANTITY	ITEM NO
---------	----------	---------

High Volume Pressure Fryers

PFE 591 Electric



PFE 591 high volume electric pressure fryer

Henny Penny first introduced commercial pressure frying to the foodservice industry more than 50 years ago. Frying under pressure enables lower cooking temperatures for longer oil life and faster cooking times to meet peak demand. Pressure also seals in food's natural juices and reduces the amount of oil absorbed into product.

Today, Henny Penny pressure fryers continue to lead the industry in performance, durability and innovation.

The Henny Penny PFE 591 cooks up to 8 head of freshly breaded bone-in chicken in a single load. For higher volume operations, that can mean significant savings in time, labor, frying oil, energy and maintenance compared to an equivalent capacity of smaller pressure fryers from other manufacturers.

Powerful, high efficiency immersed heating elements generate fast temperature recovery without sacrificing energy savings. Large loads are cooked evenly and handled easily with the patented counter-balance lift system.

Henny Penny pressure fryers have a built-in filtration system that filters and returns hot frying oil in minutes. No separate pumps and pans, no handling hot oil.

The Computron™ 8000 control features automatic, programmable operation, as well as energy-saving, filtration and cook management functions.

Standard Features

- Patented counter-balanced lid lift and lock system for easy loading and unloading
- Heavy-duty stainless steel fry pot with 7-year warranty
- Rectangular fry pot design promotes turbulence for even cooking
- Fry pot is fully insulated for energy efficient operation
- High-efficiency heating elements generate fast recovery and energy savings
- Cold zone below heating elements helps extend oil life
- High-limit temperature protection
- Lid remains in locked position until pressure reaches 1 psi
- Built-in filtration system
- Raised edge on deck reduces spills
- Stainless steel construction for easy-cleaning and long life
- 4 heavy-duty casters, 2 locking
- Computron™ 8000 control
 - 10 programmable cook cycles
 - Melt mode
 - Idle mode
 - Clean-out mode
 - Water detection alert
 - Load compensation
 - Proportional control
 - Optional filter prompt and customizable filter tracking
 - 16-character digital display with multiple language settings

Accessories shipped with unit

- Loading carrier
- Basket configuration, choose one:
 - Full basket—4 flat wire baskets, 1 wire rack cover, rack handle
 - Half-size rack—4 wire racks, 1 wire rack cover, rack handle
- Stirrer and drain clean-out rod
- Filter screen and 2 PHT filter envelopes

Accessories and options available separately

- Fryer Shortening Shuttle®
- Choose one:
 - Filter rinse hose OR
 - Direct Connect shortening disposal

<input type="checkbox"/> APPROVED	<input type="checkbox"/> APPROVED AS NOTED	<input type="checkbox"/> RESUBMIT
AUTHORIZED SIGNATURE		DATE



PROJECT

ITEM NO

High Volume Pressure Fryers

PFE 591 Electric

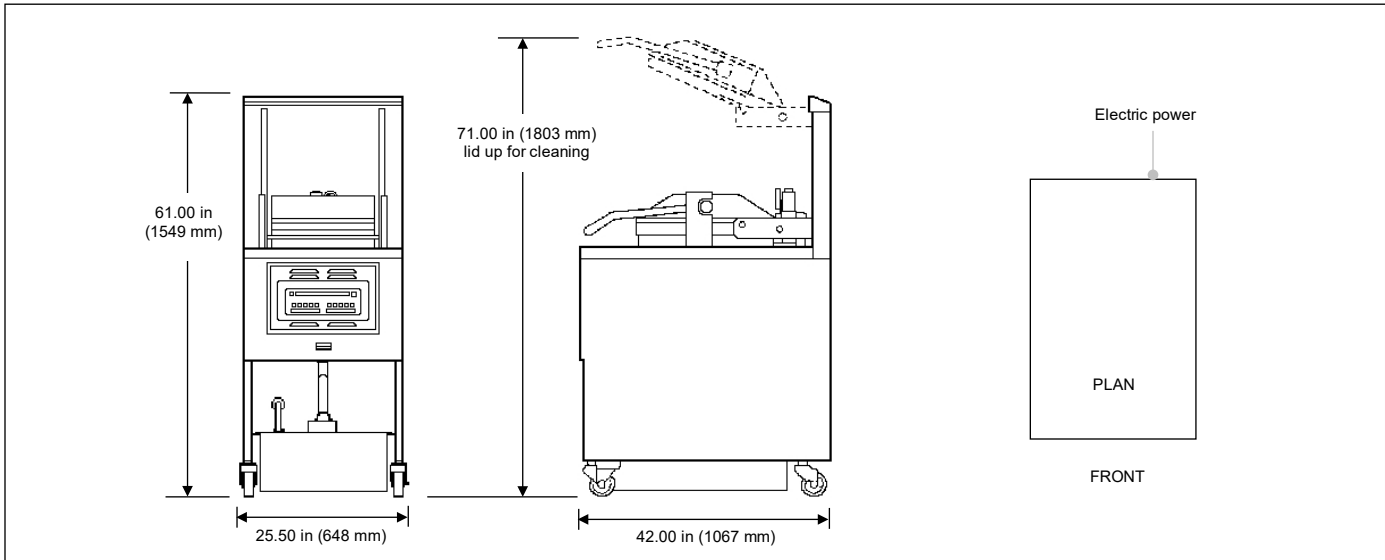

Dimensions

Height	61.00 in	(1549 mm)	to top of stack
Height	71.00 in	(1803 mm)	with lid up
Width	25.50 in	(648 mm)	
Depth	42.00 in	(1067 mm)	

Crated

Length	46 in	(1168 mm)
Depth	30 in	(762 mm)
Height	70 in	(1778 mm)
Volume	56 ft ³	(1.6 m ³)
Weight	758 lb	(344 kg)

Required clearances

Top	10 in	(254 mm)	lid up to clean
Sides	6 in	(152 mm)	air flow
Back	6 in	(152 mm)	air flow
Front	38 in	(965 mm)	remove filter pan

Pressure

Operating pressure	12.0 psi
Safety valve setting	14.5 psi

Heat

4 immersed elements
4.25 kW each/17.0 kW total

Oil capacity

100 lb or 51 L

Bidding specifications

Provide Henny Penny model PFE 591 high-volume electric pressure fryer designed to cook up to 8 head chicken per load.

Unit shall incorporate:

- Built-in filtration system
- Computron™ 8000 control system with programmable or manual operation, LED digital display, idle and melt modes, load compensation, filtration tracking and 7-day history
- Fry pot of heavy duty stainless steel with 7-year warranty
- Patented counter-balanced lid lift and lock system to seal and create and maintain 12 psi pressure in cooking chamber
- 4 heavy-duty casters, 2 locking

Electrical

Volts	Phase	Hertz	kW	Amps	Wire*	Cord & Plug Not available for all destinations
200	3	50 or 60	17.0	49.0	3+G	Please contact Henny Penny
208	3	60	17.0	47.2	3+G	
240	3	60	17.0	40.9	3+G	
380	3	50	17.0	25.8	3NG	
400	3	50	17.0	24.6	3+G	
415	3	50	17.0	23.7	3NG	
480	3	60	17.0	20.5	3+G	

Laboratory certifications



*Units shipped without power cord and plug must have power cord and plug installed on site by a qualified electrician.

Continuing product improvement may subject specifications to change without notice.

24 Hour Technical Support:
Henny Penny Technical Service
800 417.8405
technicalservices@hennypenny.com

Henny Penny Corporation
PO Box 60 Eaton OH 45320 USA
+1 937 456.8400 800 417.8417
+1 937 456.8434 Fax 800 417.8434 Fax
www.hennypenny.com

HENNY PENNY
Engineered to Last