

PROJECT	QUANTITY	ITEM NO
---------	----------	---------

Velocity Series™ Pressure Fryer

8 Head

PXE 100 Electric



VELOCITY
SERIES

Henny Penny introduced the world to commercial pressure frying over 50 years ago. Pressure fried foods absorb less oil and retain more natural juices and flavor. Pressure frying also cooks food faster at lower temperatures.

Today, Henny Penny ushers in a new generation of innovation with Velocity Series pressure fryer that not only improves product quality, but reduces cost of ownership, as well.

The Velocity Series cooks the same industry leading 8 head of freshly breaded bone-in chicken per load as our previous high volume fryer in **25% less oil!**



Large loads cook evenly and are handled easily with the patented counter-balance lift system. Two half racks fit on a standard sheet pan for holding.

Less oil in the fry pot means faster recovery and greater energy savings. But that's just the beginning.

A completely *automatic filtration* system washes food particles down the drain and filters the oil after every cook cycle in about the time it takes to rack the next load.

With *automatic oil top off*, crew never have to worry about topping off hot oil. Quality of product improves because it is always being cooked in the right amount of oil.

With less oil, frequent automatic filtering and automatic oil top-off, the Velocity Series pressure fryer can *extend oil life by 300%* compared with our previous high-volume model.

Pressure lock status monitored on control display. Low deck for better ergonomics.

Next generation touch control provides an intuitive menu style interface expandable to 160 products.

Standard Features

- Reduced volume fry pot design cooks with 25% less oil
- Fast, automatic filtration after every load extends oil life, increases productivity, and saves labor
- Automatic oil top off keeps oil fresh longer for consistent product quality
- Hidden components and rounded corners for easy cleaning
- High-efficiency heating elements for fast recovery and energy savings
- Enhanced high-limit temperature protection
- Patented counter-balanced lid lift allows one handed operation
- Automatic cook-cycle pressure lock
- Pressure lock status monitored
- Fully insulated fry pot for energy efficient operation
- Heavy-duty stainless steel fry pot with 7-year warranty
- 4 heavy-duty casters, front locking
- Next generation control
 - 3 line menu style digital display with capacitive touch keys
 - 50 programmable products expandable to 160
 - USB support for product upload
 - Extended memory for months of activity logging, management reports, or diagnostics
 - Auto Startup mode with melt, stir, top off, polish, and idle cycles
 - Monitors pressure lock and displays status and alerts
 - Water detection alert

- Load compensation cycle time
- Proportional heat pulse control

Accessories shipped with unit

- Loading carrier and cover rack
- 4 wire baskets and basket handle
- Quick-connect drain pan
- Large capacity crumb catcher
- Quick-connect filter screen
- 2 filter screen clips with handles
- 100 PHT filter envelopes
- 3 brushes and fry pot scraper

Available options and accessories

- Bulk oil disposal system with front and rear dispose connections
- Additional baskets or half racks
- ODS 310 50 lb oil disposal shuttle

<input type="checkbox"/> APPROVED	<input type="checkbox"/> APPROVED AS NOTED	<input type="checkbox"/> RESUBMIT
AUTHORIZED SIGNATURE		DATE



PROJECT	ITEM NO
---------	---------

Velocity Series™ Pressure Fryer

8 Head

PXE 100 Electric

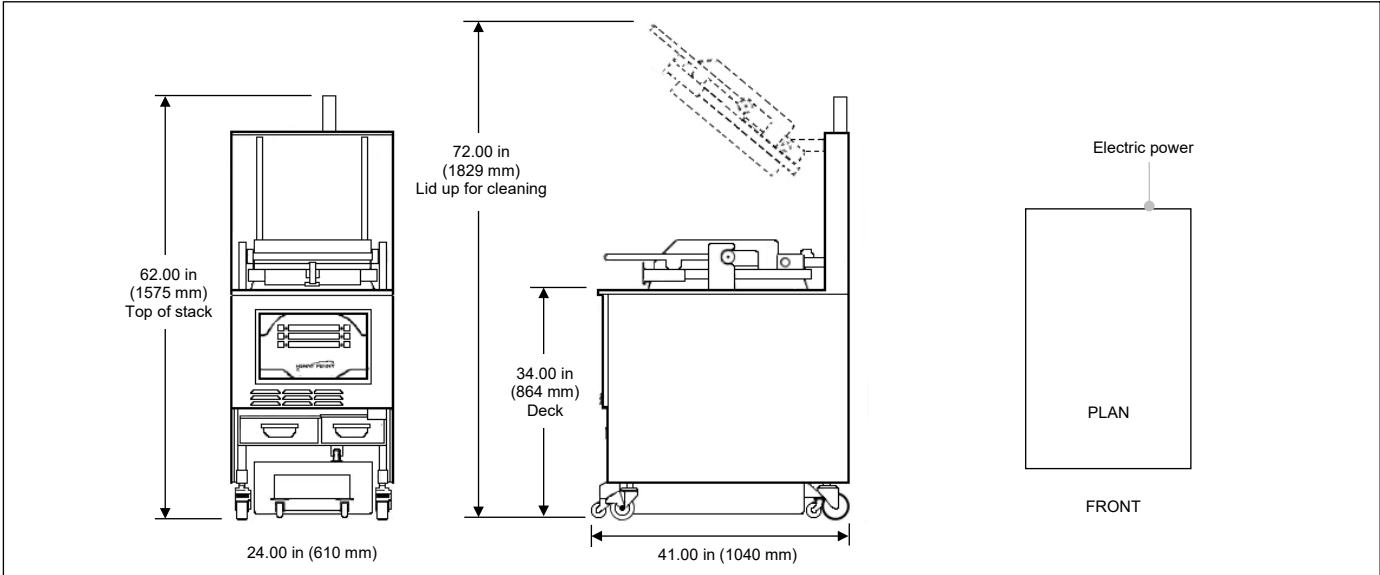

Dimensions

Height 62.00 in (1575 mm) to top of stack
 Height 72.00 in (1829 mm) lid up to clean
 Width 24.00 in (610 mm)
 Depth 41.00 in (1041 mm)

Crated

Length 45 in (1143 mm)
 Depth 30 in (762 mm)
 Height 65 in (1651 mm)
 Volume 51 ft³ (1.44 m³)
 Weight 877 lb (398 kg)

Required clearances

Top 6 in (152 mm) lid up to clean
 Sides 6 in (152 mm) air flow
 Back 6 in (152 mm) air flow
 Front 38 in (965 mm) remove filter pan

Pressure

Operating pressure 12.0 psi
 Safety valve setting 14.5 psi

Heat

4 immersed elements
 4.25 kW each/17.0 kW total

Oil capacity

Fry pot 75 lb or 38 L
 Reservoir 15 lb or 8 L

Bidding specifications

Provide Henny Penny Velocity Series model PXE 100 high-volume electric pressure fryer designed to cook up to 8 head chicken per load in 75 lb or 38 L oil.

Unit shall incorporate:

- Automatic filtration
- Automatic oil top-off
- Next generation control system with 50 programmable cook cycles expandable to 160, plus 3-line menu style digital display, pressure lock status, USB support, Auto Startup and full suite of energy and oil management modes
- Patented counter-balanced lid lift
- Pressure lock seals, creates and maintains 12 psi pressure in cooking chamber
- Seamless stainless steel deck
- Fry pot of heavy duty stainless steel with 7-year warranty
- Oil drain pan with 4 casters, large capacity crumb catcher, quick-connect filter screen and lock-in system with sensor warning when pan is not properly locked into place
- 4 heavy-duty casters, front locking
- Loading carrier with 4 half baskets, 1 cover rack, and basket handle
- Gong brush, straight brush, L tip brush, and fry pot scraper

Electrical

Volts	Phase	Hertz	kW	Amps	Wire*	Cord & Plug
208	3	60	17.0	47.2	3+G	Not available for all destinations 7 ft power cord and plug 208 V, 240 V only  NEMA 15-60P right angle
240	3	60	17.0	40.9	3+G	
380	3	50	17.0	25.8	3NG	
415	3	50	17.0	23.7	3NG	
480	3	60	17.0	20.5	3+G	

Laboratory certifications



*Units shipped without power cord and plug must have power cord and plug installed on site by a qualified electrician.

Continuing product improvement may subject specifications to change without notice.

24 Hour Technical Support:
 Henny Penny Technical Service
 800 417.8405
technicalservices@hennypenny.com

Henny Penny Corporation
 PO Box 60 Eaton OH 45320 USA
 +1 937 456.8400 800 417.8417
 +1 937 456.8434 Fax 800 417.8434 Fax
www.hennypenny.com

